

C.A. Technologies

Bandit 2 Quart

51-600(A) & 51-602(A)

2 QUART PRESSURE CUP PART SHEET
PRODUCT INFORMATION



51-600 SINGLE REGULATED
51-602 DOUBLE REGULATED
51-600A AGITATED (1 REG)
51-602A AGITATED (2 REG)

The Bandit 2 quart pressure cup features a stainless steel clamp band which provides 360 degree clamp pressure between the lid and canister.

51-600 Bandit Pressure Cup Assembly

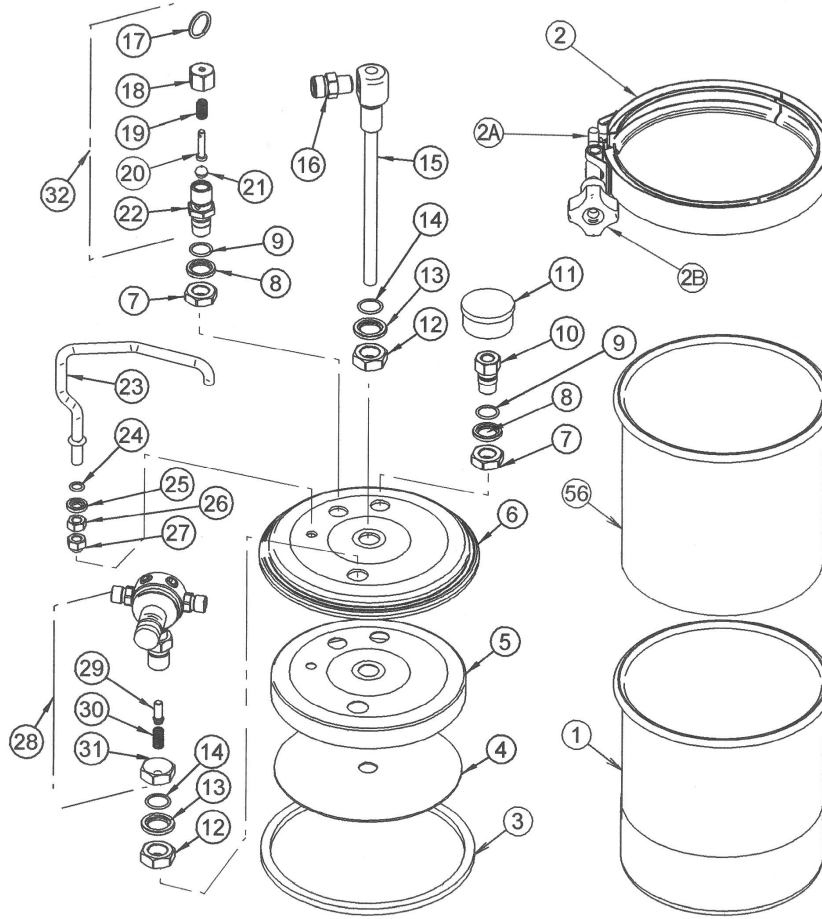

ITEM NO.	PART NO.	DESCRIPTION	ITEM NO.	PART NO.	DESCRIPTION
1	51-634	Cannister	17	51-623	Pull Ring
2	51-611	Band Clamp	18	51-638	Relief Valve Cap
2A	51-645	T-Bolt for Band	19	51-618	Relief Valve Spring
2B	51-646	Knob for Band - Cast Iron	20	51-631	Relief Valve Stem
3	51-620-5	Gasket (5 Pack)	21	98-0132	Ball
4	51-633	Splash Guard	22	51-617	Pressure Relief Body
	51-657	Splash Guard (Agitated)	23	51-642	Handle
5	51-613	Inner Lid		51-667	Handle (Agitated)
6	51-635E	Outer Lid	24	98-8011	O-Ring
7	98-0119	9/16-18 Locknut	25	51-629	Seal Plate
8	51-632	Seal Plate	26	98-0118	5/16-18 Locknut
9	98-8015	O-Ring	27	98-0124	Acorn Nut
10	51-624	Pressure Gage Fitting	28	51-616	Regulator Assembly
11	52-53 (standard)	Pressure Gage (0 to 15 PSI)	Not Show n	52-222-Reversed	Optional 2nd Regulator**
	52-52 (optional)	Pressure Gage (0 to 60 PSI)*	29	51-636	Check Poppet
12	98-0120	5/8-18 Locknut	30	51-619	Spring
13	51-628	Seal Plate	31	51-643	Retaining Cap
14	98-8016	O-Ring	32	51-630	Relief Valve Assembly
15	51-625	Fluid Outlet Assembly	33	51-644	Spacer (15 PSI Regulator)
16	53-555	Fluid Outlet Nipple	56	51-637-12	Plastic Liner (12 Pack)

*To convert unit to 0-50 PSI, remove item 33 and replace pressure gage with P/N 52-52

**Second regulator to convert unit to double regulated (51-222)

51-670 Bandit Agitator Sub-Assembly

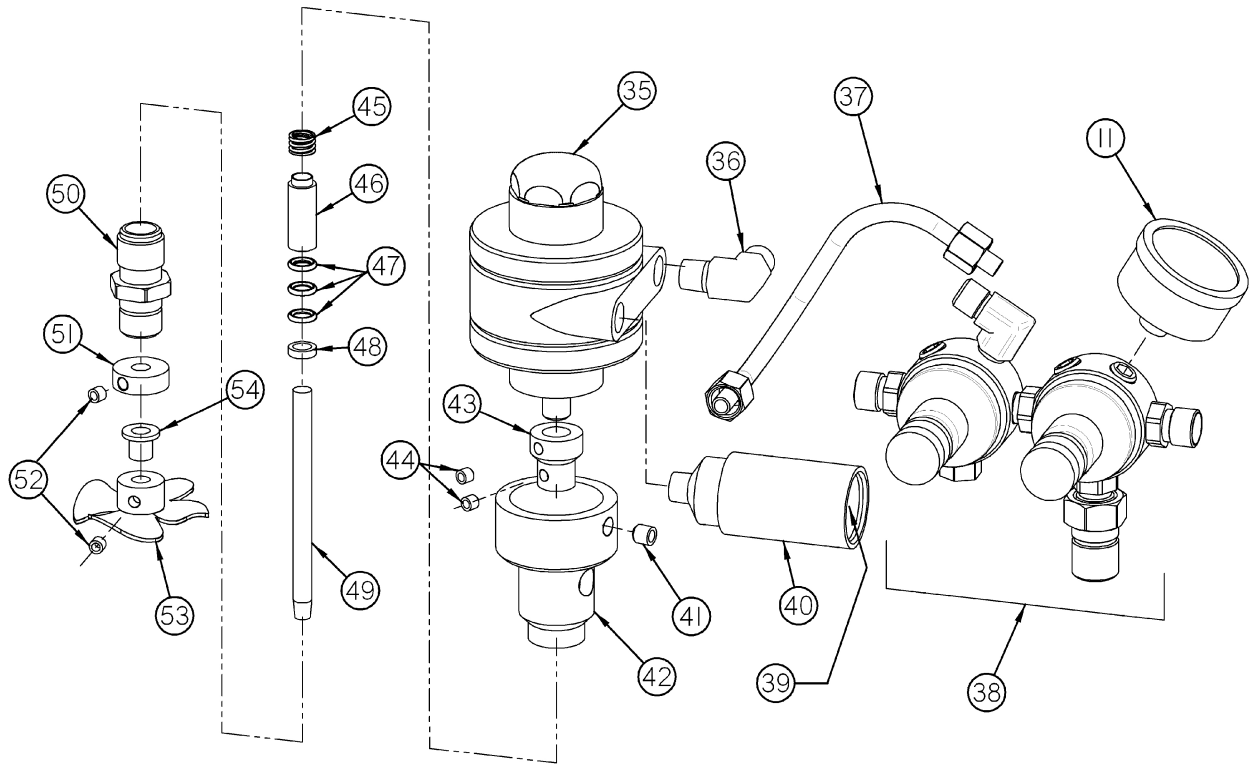

ADDITIONAL PARTS FOR AGITATED VERSION 51-650A ONLY (51-670 AGITATOR SUB-ASSEMBLY)

ITEM NO.	PART NO.	DESCRIPTION	ITEM NO.	PART NO.	DESCRIPTION
34	51-658	Splash Guard Retainer	48	51-654	Lower Shaft Guide
35	51-677	Air Motor	49	51-651	Agitator Shaft
36	98-0182	Elbow Fitting	50	51-653	Seal Housing
37	51-663	Hose Assembly	51	51-659	Slinger Ring
38	51-669	Dual Regulator Assembly	52	98-0179	Set Screw
40	51-271	Muffler Assembly	53	51-648	Impeller
41	98-0178	Set Screw	54	51-649	Impeller Sleeve
42	51-676	Motor Base	55	51-671	Splash Guard Spacer
43	51-678	Shaft Coupling	Not Show n	10-5	Regulator Repair Kit
44	98-0178	Set Screw	Not Show n	10-120	Air Motor Rebuild Kit
45	51-656	Seal Spring	Not Show n	10-121	Shaft Seal & Bearing Kit
46	51-655	Upper Shaft Guide	Note: Air motor performance is not guaranteed after field repair. Factor repair of air motor is recommended for best results.		
47	98-8010	O-Ring			

*To convert unit to 0-50 PSI, remove item 33 and replace pressure gage with P/N 52-52

**Second regulator to convert unit to double regulated (51-222)

WARNING! MAX WORKING PRESSURE 50 PSI

REMOVE THE LID

COMPLETELY RELIEVE PRESSURE IN CANISTER BEFORE ATTEMPTING TO REMOVE THE LID!

1. Loosen the clamp knob completely until it stops (by holding the clamp ends together with one hand the knob can be loosened to the stop rapidly).
2. Disengage the T-bolt from one end of the clamp, spread the clamp only as much as necessary to clear the lid and lower clamp down around the canister.

INSTALLING LID AND CLAMP

1. Place lid assembly on canister; it is self centering with the canister.
2. With the T-bolt disengaged, spread the clamp and place into position from above the lid.
3. Engage the T-bolt into the end of the clamp and tighten the knob. (By drawing the clamp ends together with one hand, the knob can be advanced rapidly before final tightening).

Anti-Tip Stand 51-672



Rigid Liners 51-637-12

